

# Underfloor Heating - Manifold

## with Pressure Independent Control (PICV)

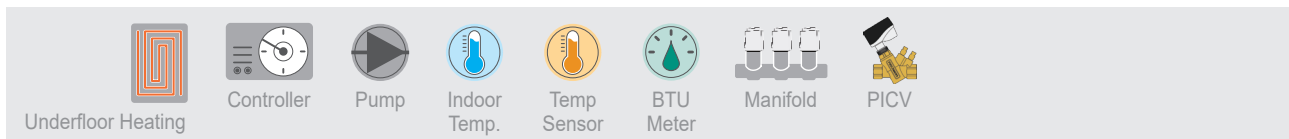
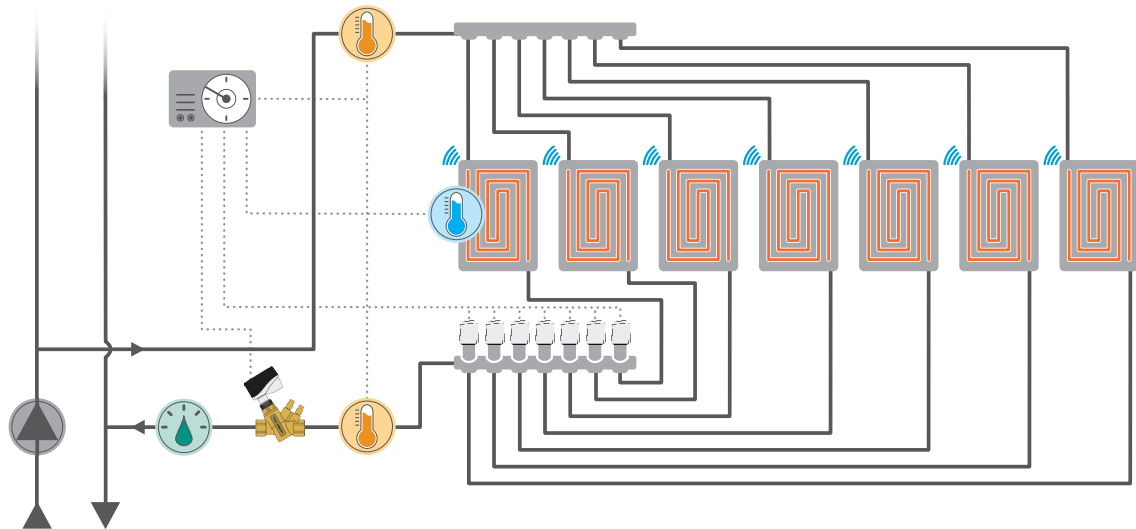

### System Functionality:

In well-insulated buildings, water-based underfloor heating provides several advantages over conventional radiators when considering acceptable room temperature. Heat is distributed more evenly, cold feet are avoided and consequently the indoor temperature may be reduced by 1° or 2°C without feeling cold, resulting in energy savings. Underfloor heating will also work at lower supply temperature and low flow rates. Room temperature is controlled by thermal actuators, but without further system balancing, poor control may become a problem. This can be solved by installing a Pressure Independent Control Valve (PICV) as zone valve in connection with each manifold controlling both flow and pressure in the zone.

### Requirements:

The PICV will react to system pressure changes and regulate the flow of low temperature hot water to required flow by adjusting the actuator position. This helps to secure a steady temperature in the entire underfloor heating system.

### Solutions:

The solution is to mount a PICV on every manifold and FlowCon offers:

- FlowCon Green / GreEQ (adjustable insert)
- FlowCon UniQ® (built-in regulation unit)

### Benefits:

- Assures correct flow for each unit automatically - also at partial loads - securing optimal comfort
- Serviceable insert-design solution (Green / GreEQ)
- Energy efficiency with regulation starting at only 10 kPaD (UniQ®)
- Flexible solution with minimum 41 different and stepless max. flow settings
- Electrical actuators with selectable control mode, linear or equal% or alternatively thermal ON/OFF actuators
- Cost savings due to reduced commissioning time
- True PICVs - 100% authority and pressure independency at all flow rates with accurate actuator control.

FlowCon PICVs



# Underfloor Heating - Single Circuit

## with Pressure Independent Control (PICV)

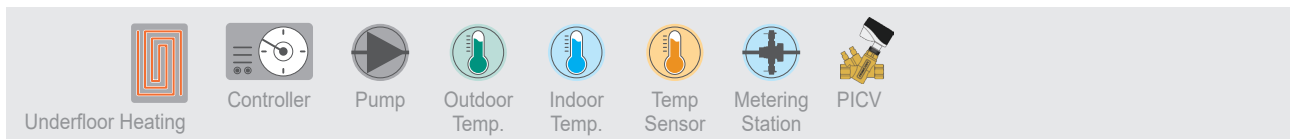
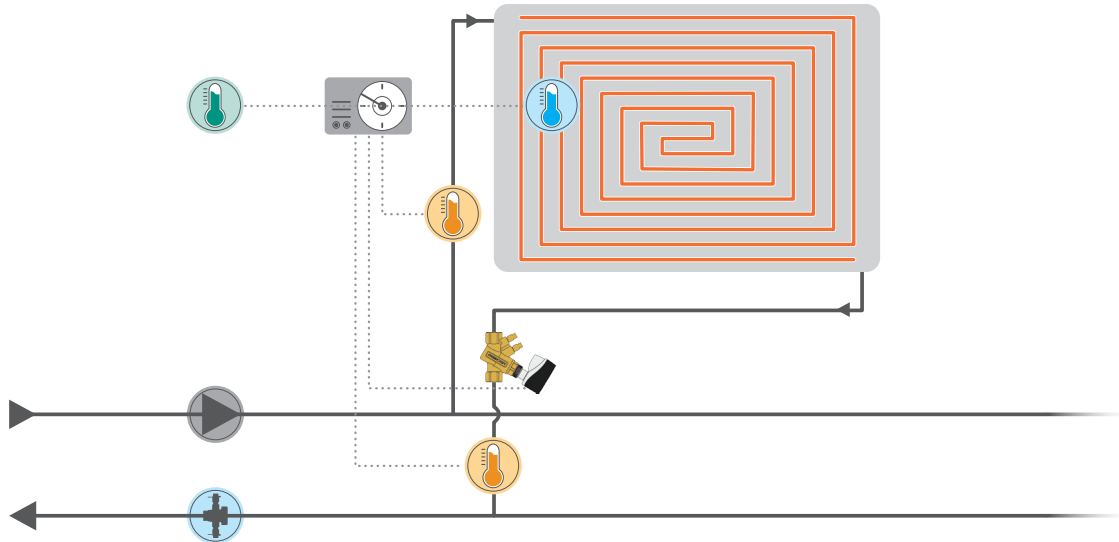

### System Functionality:

In well-insulated buildings, water-based underfloor heating provides several advantages over conventional radiators when considering acceptable room temperature. Heat is distributed more evenly, cold feet are avoided and consequently the indoor temperature may be reduced by 1° or 2°C without feeling cold, resulting in energy savings. Underfloor heating will also work at lower supply temperature and low flow rates. Room temperature is controlled by thermal actuators, but without further system balancing, poor control may become a problem. This can be solved by installing a Pressure Independent Control Valve (PICV) on the underfloor heating circuit efficiently controlling both flow and pressure.

### Requirements:

The PICV's full authority and ability to accurately control actuator position to required flow of low temperature hot water or even close completely is important. This helps to secure a steady temperature in the underfloor heating circuit.

### Solutions:

The solution is to mount a PICV on the underfloor heating circuit and FlowCon offers:

- FlowCon Green / GreEQ (adjustable insert)
- FlowCon UniQ® (built-in regulation unit).

### Benefits:

- Assures correct flow automatically - also at partial loads - securing optimal comfort
- Serviceable insert-design solution (Green / GreEQ)
- Energy efficiency with regulation starting at only 10 kPaD (UniQ®)
- Flexible solution with minimum 41 different and stepless max. flow settings
- Electrical actuators with selectable control mode, linear or equal% or alternatively thermal ON/OFF actuators
- Cost savings due to reduced commissioning time
- True PICVs - 100% authority and pressure independency at all flow rates with accurate actuator control.

FlowCon PICVs

