

System By-Pass - Plant Room

with Automatic Balancing

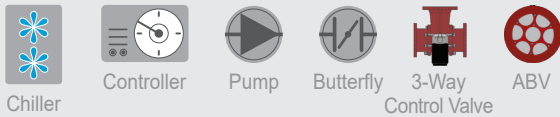
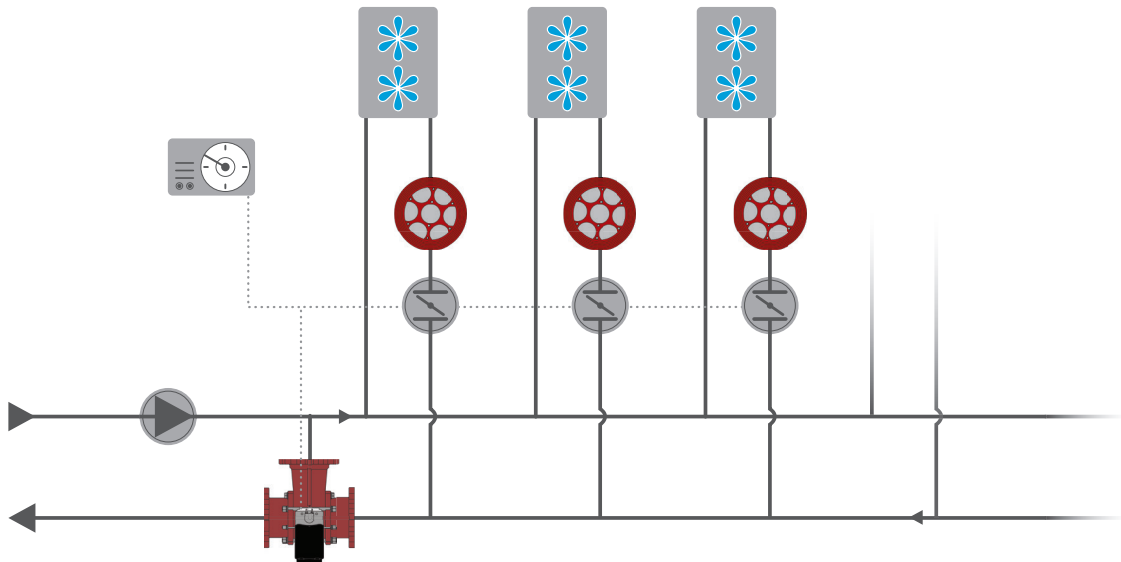

System Functionality:

Plant room system by-pass includes a 3-way control valve and Automatic Balancing Valves (ABV) on each terminal. In the starting position and with all water required through the terminals, the by-pass will be closed. At reduced loads, the terminal units are to be isolated hence reducing the flow requirements. If the flow requirement is below pump capacity - or below minimum VFD frequency - the control valve by-pass is to be opened through the BMS system to ensure minimum flow in the pump, protecting the pump and preventing system vibrations. The ABV installed on the thermal unit will ensure that the unit receives the same flow rate regardless of the number of thermal units in operation. This ensures optimal working conditions of the operational terminals thereby optimizing unit efficiency and improving energy efficiency of the system.

Requirements:

An ABV will react to system pressure changes and limit the water flow to required max. flow helping the system water balance even with pressure changes for instance when some chillers in the same system are ramped off.

Solutions:

The solution is to mount a 3-way control valve on the plant room by-pass for flow relief and ABVs on every single unit and FlowCon offers:

- FlowCon Wafer (pre-set multiple inserts)
- FlowCon Unimizer®.

Benefits:

- Assures no overflow in the system
- An easy-to-use solution
- Energy efficiency with regulation starting at only 10 kPaD
- Range of Optimizer® parabolic flow inserts available or each Unimizer® size - True equal% flow characteristics
- Allows high close-off pressure
- Cost savings due to reduced time to install, balance and commission
- A proven technology - long life expectancy
- Assures relief at low flow.

